

# Synthesis of the perdeuterated cellulose solvents *N*-methylmorpholine *N*-oxide (NMMO- $d_{11}$ ) and *N,N*-dimethylacetamide (DMAc- $d_9$ )

Christian Adelwöhrer,<sup>a</sup> Yuko Yoneda,<sup>a</sup> Fumiaki Nakatsubo,<sup>b</sup> and Thomas Rosenau<sup>a\*</sup>

The synthesis of the perdeuterated cellulose solvents NMMO- $d_{11}$  (**9**) and *N,N*-dimethylacetamide- $d_9$  (**14**) is described. NMMO- $d_{11}$  was obtained according to a five-step approach from non-labeled diglycolic acid (**1**) via diethylene glycole- $d_8$  (**4**) and its bis-tosylate (**5**), which underwent cyclization with benzylamine to *N*-benzylmorpholine (**6**). The removal of the benzyl protecting group, methylation and *N*-oxidation completed the synthesis. DMAc- $d_9$  (**14**) was obtained from deuterated acetic acid (**10**) and dimethylamine-carbon dioxide complex (**17**) with acidic alumina as the catalyst according to a solvent-free gas-solid reaction.

**Keywords:** cellulose solvents; amine *N*-oxides; substituted acetamides; polysaccharides; NMR

## Introduction

The dissolution of cellulose, its stepwise mechanism and its molecular basics, have been in the research focus for decades and are still unsolved problems in polysaccharide chemistry. A suitable and promising technique to tackle the dissolution problem on a molecular level is NMR spectroscopy, which requires deuterated solvents for studies in the proton domain.

Herein we would like to communicate the synthesis of two perdeuterated cellulose solvents, *N*-methylmorpholine *N*-oxide monohydrate (NMMO, **9**) and *N,N*-dimethylacetamide (DMAc, **14**), to be used in cellulose dissolution studies by NMR. In both approaches, all steps were comprehensively optimized with regard to yield by means of a non-labeled starting material, before entering the 'hot runs' with deuterated compounds.

NMMO, a crystalline solid that forms tractable dopes with cellulose at temperatures above 100°C and 'solid solutions' at room temperature (r.t.), is the only solvent for cellulose used on an industrial scale, being the basis of the Lyocell technology. On laboratory scale, NMMO can be applied together with co-solvents, such as DMSO or amines, to obtain liquid solutions at r.t. DMAc, a viscous colorless liquid at r.t. commonly applied in combination with 0.9–9% (w/v) LiCl, has become a standard solvent for gel permeation chromatography (GPC) studies of cellulose.

## Results and discussions

After testing several alternatives in non-optimized runs with non-labeled starting materials, we focused on the synthesis shown in Scheme 1 (i: MeOH/conc. H<sub>2</sub>SO<sub>4</sub> (cat.), reflux, 24 h,

90%; ii: NaOMe/MeOD, r.t., 8 d, 95%; iii: LiAlD<sub>4</sub>, THF, –10 to 40°C, 90%; iv: TsCl/NaOH, H<sub>2</sub>O/THF, 0°C to r.t., 24 h, 86%; v: BnNH<sub>2</sub>, dioxane, 100°C, 14 h, 98%, vi: H<sub>2</sub>, Pd/C, CH<sub>2</sub>Cl<sub>2</sub>/MeOH, r.t., 7 d, 99%; vii: (CD<sub>2</sub>O)<sub>n</sub>/DCOOD, reflux, 14 h (not isolated); viii: 30% H<sub>2</sub>O<sub>2</sub>, r.t., 2 h, 72%). The approach allows for later modifications with regard to the introduction of a second isotopic label (<sup>13</sup>C or <sup>15</sup>N) without having to change the overall sequence. The yields of each step were boosted above 90% by optimization.

In the starting step, commercially available and inexpensive diglycolic acid (**1**) was converted into its dimethyl diester **2** (90%) in the presence of catalytic amounts (0.1% rel. to **1**) of sulfuric acid. Larger amounts favored the formation of the bislactone [1,4]dioxane-2,5-dione. Dimethyl diglycolate (**2**) underwent H/D-exchange (>99%) in CD<sub>3</sub>OD/CH<sub>3</sub>ONa. The obtained tetradeutero-diglycolic acid dimethylester (**3**) was used without further purification in the subsequent reduction (LiAlD<sub>4</sub> in THF),<sup>1</sup> providing diethylene glycol- $d_8$  (**4**). During addition of the reducing reagent, the reaction temperature must not exceed –10°C, whereas subsequent heating of the mixture is crucial to ensure a complete reaction at 'both sides' of the diglycolate. During the work-up the amount of water (i.e.

<sup>a</sup>Department of Chemistry, University of Natural Resources and Applied Life Sciences (BOKU), Muthgasse 18, A-1190 Vienna, Austria

<sup>b</sup>Graduate School of Agriculture, Kyoto University, Sakyo-ku, Kyoto 606-8502, Japan

\*Correspondence to: Thomas Rosenau, Department of Chemistry, University of Natural Resources and Applied Life Sciences (BOKU), Muthgasse 18, A-1190 Vienna, Austria.

E-mail: thomas.rosenau@boku.ac.at

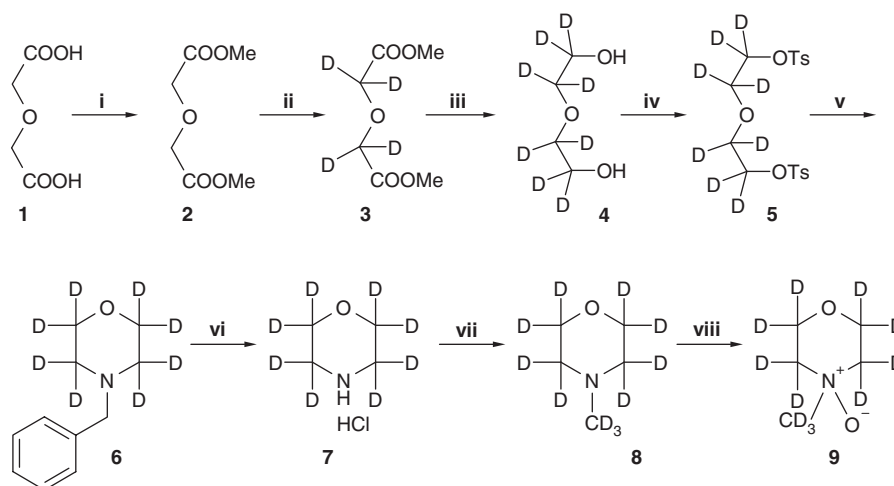

Scheme 1

aqueous acid) needed to dissolve the aluminum salts should be kept as small as possible to avoid problems in the separation and purification. Bis-tosylation of **4** in water with tosyl chloride and sodium hydroxide as the base provided the bis-tosylate **5** (86%) as a white solid.<sup>2</sup> This procedure was superior to alternative approaches working in non-aqueous organic solvents under amine catalysis.

The cyclization reaction<sup>3</sup> of bis-tosylate **5** proceeded best with 5 equivalents of benzyl amine in dry 1,4-dioxane in the presence of anhydrous MgSO<sub>4</sub> under strictly anhydrous conditions, affording *N*-benzyl-octadeuteromorpholine (**6**) in 99% yield. A variant, working with an equimolar amount of benzylamine in DMF with K<sub>2</sub>CO<sub>3</sub> as the auxiliary base (76% yield), is useful for the introduction of <sup>15</sup>N-labeling, as the high costs of <sup>15</sup>N-benzyl amine prevent its use in a fivefold excess. Compound **6** was purified by preparative column chromatography – the only chromatographic purification step required in the eight-step synthesis sequence toward perdeuterated NMMO.

*N*-benzyl-octadeuteromorpholine (**6**) was debenzylated at atmospheric pressure in MeOH/CH<sub>2</sub>Cl<sub>2</sub> with 10% Pd/C forming directly octadeuteromorpholine hydrochloride (**7**) in 98% yield.<sup>3</sup> Upon hydrogenation, the solvent system releases hydrochloric acid which concomitantly converts the released amine into its hydrochloride. Hydrochloride **7** was directly converted into *N*-methylmorpholine-d<sub>11</sub> (**8**) according to an Eschweiler–Clarke protocol<sup>4</sup> and oxidized without further purification with 2 equivalents of 30% H<sub>2</sub>O<sub>2</sub><sup>4</sup> added slowly at 0°C. The target compound NMMO-d<sub>11</sub> (**9**) was purified by Kugelrohr sublimation in high vacuum. Caution should be exercised that the temperature does not exceed 130°C due to the instability of NMMO strongly increasing above this threshold temperature. The overall yield of NMMO-d<sub>11</sub> (**9**) was 46% relative to the starting diglycolic acid (**1**) and 72% relative to the key intermediate octadeuteromorpholine hydrochloride (**7**).

Two general pathways toward perdeuterated *N,N*-dimethylacetamide (**14**) proved to be viable, the reaction of dimethylamine with an acetylating agent and the *N,N*-bismethylation of acetamide. Following the latter approach, acetic acid-d<sub>4</sub> (**10**) was converted into its isopropyl ester (**11**) in the presence of catalytic amounts of concentrated H<sub>2</sub>SO<sub>4</sub>, and further into acetamide-d<sub>3</sub> (**12**) by treatment with aqueous ammonia. At this

point, <sup>15</sup>N-labels can also be introduced employing ammonia-<sup>15</sup>N. Subsequent bismethylation with methyl iodide-d<sub>3</sub> provided only unsatisfactory results. The alternative reductive methylation approach proceeded neatly to the *N,N*-bis(hydroxydeuteromethyl) intermediate **13**,<sup>5</sup> which is in agreement with literature,<sup>5</sup> but gave rather disappointing yields of less than 40% in the subsequent reduction to *N,N*-dimethylacetamide-d<sub>9</sub> (**14**) with formic acid-d<sub>2</sub>. The use of alternative reductants, such as NaBD<sub>4</sub>, LiAlD<sub>4</sub>, and Zn/DCl, was even inferior. In the overall sequence, the yield of *N,N*-dimethylacetamide-d<sub>9</sub> (**14**) referred to acetic acid-d<sub>4</sub> (**10**) was 24% (Scheme 2, **i**: *i*-PropOH, H<sup>+</sup> (cat.), reflux, 1.5 h (92%); **ii**: NH<sub>3</sub> (conc.), 0°C to r.t., 30 min (62%); **iii**: (CD<sub>2</sub>O)<sub>*n*</sub>, DCOOD, reflux, 8 h (42%, overall (**14** from **10**): 24%). Due to these yield penalties, especially in the bismethylation step, the following alternative approach toward **14** involving amide formation of acetic acid with dimethylamine was preferred.

The key step in this synthesis was the reaction of dimethylamine with carbon dioxide to the liquid 2:1 addition product (**17**), sometimes referred to as 'dimcarb'.<sup>6</sup> This product is a colorless liquid at ambient conditions which decomposes reversibly at 60°C into the gaseous components, HNMe<sub>2</sub> and CO<sub>2</sub>. The compound can well be imagined as a 'distillable ionic liquid'. In liquid phase, the neutral addition product between *N,N*-dimethylcarbamic acid and dimethylamine (**17a**) is present in equilibrium with its ionic tautomer, the salt *N,N*-dimethylammonium *N,N*-dimethylcarbamate (**17b**), both undergoing complex prototropic interactions.<sup>6</sup> The formation of **17** was not directly involved in the formation of DMAC, but used instead for improving the handling and purification of *N,N*-di(trideuteromethyl)amine (**16**).

In a first step, ammonia – introduced in the form of the exactly dosable ammonium carbonate **15** – reacted with methanol-d<sub>4</sub> at 350°C in an autoclave, in the presence of acidic aluminum oxide (Brockmann grade I) which acted as both as alkylation catalyst and as trap of water.<sup>7,8,9</sup> Applied in a molar ratio of 1:2, ammonium carbonate and methanol-d<sub>4</sub> afforded a mixture of 4% of non-reacted ammonia (b.p. –33°C), 16% methylamine (b.p. –6.3°C), 56% of dimethylamine (b.p. 7°C) and 24% of trimethylamine (b.p. 4°C). Only dimethylamine formed a stable and 'distillable' liquid addition product with CO<sub>2</sub>, whereas the other products remained gaseous.

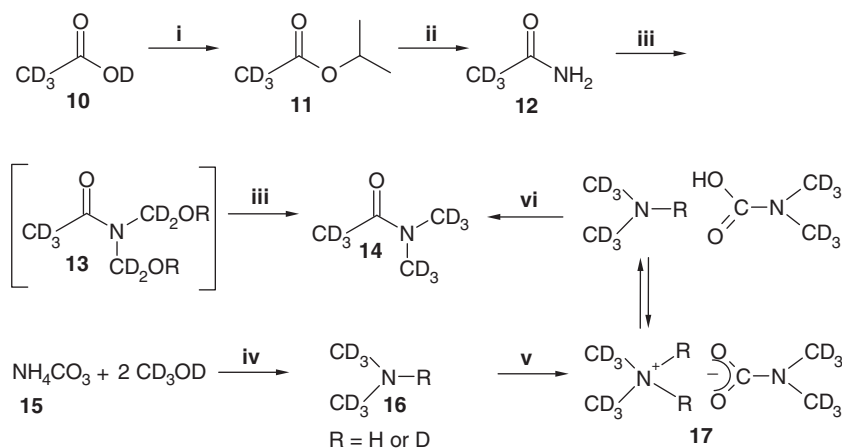

Scheme 2

Intermediate (**17**) was further reacted in an autoclave at 250°C with acetic acid-d<sub>4</sub> (**10**) in the presence of the same acidic aluminum oxide catalyst (Brockmann grade I) used in the previous step.<sup>10</sup> Quantitative conversion was achieved in a neat gas phase/solid phase reaction within 1 h, and the alumina was easy to separate by simple filtration. The use of sulfuric acid as catalyst as proposed in the literature<sup>11</sup> was less suitable: the catalyst needed to be separated from the product by extraction and yields were about 90%, but not quantitative. The reaction temperature of 250°C should not be lowered to avoid significant yield penalties. This alternative synthesis approach provided *N,N*-dimethylacetamide-d<sub>9</sub> (**14**) in quantitative yields relative to acetic acid-d<sub>4</sub> (**10**), and in 56% yield relative to ammonium carbonate (**15**), see Scheme 2. **iv**: autoclave, 350°C, 3 h; **v**: CO<sub>2</sub>, 5 bar, 3 h, r.t. to 80°C to r.t. (56% from **15**); **vi**: **10** (1 eq.), acidic Al<sub>2</sub>O<sub>3</sub>, autoclave, 250°C, 1 h (overall: 100% from **10**, 56% from **15**).

## Experimental

**Materials:** All chemicals were commercially available. Thin-layer chromatography (TLC) was performed on silica gel 60 plates (5 × 10 cm, 0.25 mm) with fluorescence detection under UV light at 254 nm. Column chromatography was performed on silica gel G60 plates (40–63 mm). Melting points, determined on a Kofler-type micro hot stage with Reichert–Biovar microscope, are uncorrected. <sup>1</sup>H NMR spectra were recorded at 400.13 MHz, <sup>13</sup>C NMR spectra at 100.42 MHz in CDCl<sub>3</sub> as the solvent and TMS as the internal standard, if not stated otherwise. NMR data are given for the deuterated compounds and also for non-deuterated title products and key intermediates for comparison.

**Tetradecutero-diglycolic acid dimethylester (3):** Diglycolic acid (6.70 g, 50 mmol) was refluxed in dry methanol (50 ml) containing a catalytic amount of sulfuric acid (0.2 ml) for 24 h. The solution was concentrated, water was added and the mixture was repeatedly extracted with dichloromethane to obtain the pure dimethylester. Sodium metal (0.50 g, 22 mmol) was dissolved in water-free MeOD (50 ml) and the dimethylester just obtained was added to this solution and stirred for 24 h under nitrogen at r.t. The MeOD was evaporated and a fresh portion of MeOD was added and the mixture was stirred for another 24 h. Replacement of the 'used' MeOD by 'fresh' one was repeated until the proton peak in <sup>1</sup>H NMR completely

disappeared, usually requiring 7–8 days. Finally, the MeOD was removed. After addition of D<sub>2</sub>O (50 ml) the aqueous phase was extracted five times with dichloromethane, and the extracts were combined. After removing the solvent *in vacuo*, deuterated compound **3** (7.14 g, 86%) was obtained as a transparent liquid. <sup>1</sup>H NMR (CD<sub>3</sub>OD): δ 3.73 (s, 6H, OCH<sub>3</sub>). <sup>13</sup>C NMR (CD<sub>3</sub>OD): δ 50.9 (OCH<sub>3</sub>), 67.0 (m, J<sub>C,D</sub> = 22 Hz), 170.7 (COO).

**Octadeutero-diethylene glycol (4):** LiAlD<sub>4</sub> (2.1 g, 50 mmol) was added to absolute THF (50 ml) under a nitrogen atmosphere. The flask was cooled to –10°C and dimethyl diglycolate (7.00 g, 42 mmol) dissolved in dry THF (100 ml) was added during 45 min. The reaction mixture was warmed to 40°C and stirred for another 30 min. The excess of LiAlD<sub>4</sub> was destroyed by dropwise addition of water. The solids were filtered and washed thoroughly with THF. Then the solvent was removed *in vacuo*, and the crude compound **4**, obtained as colorless oil, was used for next step without further purification. <sup>1</sup>H NMR: δ 4.51 (s, br, 2H, OH). <sup>13</sup>C NMR: δ 60.8 (pent, J<sub>C-D</sub> = 21 Hz, CD<sub>2</sub>OH), 71.4 (pent, J<sub>C,D</sub> = 21.0 Hz, CD<sub>2</sub>-O-CD<sub>2</sub>).

**Octadeutero-diethylene glycol ditosylate (5):** NaOH (3.44 g) was dissolved in water (16 ml) and diethylene diglycol-d<sub>8</sub> (2.88 g, 24.54 mmol) was added. The mixture was cooled to 0°C, tosyl chloride (10.3 g, 53.99 mmol) in THF (25 ml) was added dropwise over a period of 2 h, and the mixture was stirred for 16 h. After addition of 10% HCl (200 ml) stirring was continued for additional 30 min. The precipitated compound was filtered and extensively washed with aqueous potassium carbonate solution (2%) and water. Drying *in vacuo* provided ditosylate **5** (9.01 g, 87%) as a white powder, m.p. = 86–87°C. <sup>1</sup>H NMR: δ 2.45 (s, 6H, CH<sub>3</sub>), 7.35 (d, <sup>3</sup>J = 8.4 Hz, 4H, Ar-CH), 7.78 (d, <sup>3</sup>J = 8.4 Hz, 4H, Ar-CH). <sup>13</sup>C NMR: δ 21.6 (2C, CH<sub>3</sub>), 68.3 (m, 4C, CD<sub>2</sub>-CD<sub>2</sub>, J<sub>C,D</sub> = 21 Hz), 128.0 (4C, <sup>Ar</sup>C-2/6), 129.8 (4C, <sup>Ar</sup>C-3/5), 132.6 (2C, <sup>Ar</sup>C-4), 144.8 (2C, <sup>Ar</sup>C-1). Comparison with the non-deuterated product (diethylene glycol ditosylate): <sup>1</sup>H NMR: δ 2.45 (s, 6H, CH<sub>3</sub>), 3.60 (t, 4H, <sup>3</sup>J = 3.5 Hz, CH<sub>2</sub>-O-CH<sub>2</sub>), 4.09 (t, 4H, <sup>3</sup>J = 3.5 Hz, CH<sub>2</sub>-O-Tos), 7.35 (d, <sup>3</sup>J = 8.4 Hz, 4H, Ar-CH), 7.78 (d, <sup>3</sup>J = 8.4 Hz, 4H, Ar-CH). <sup>13</sup>C NMR: δ 21.6 (2C, CH<sub>3</sub>), 68.7 (2C, CH<sub>2</sub>), 69.0 (2C, CH<sub>2</sub>), 127.9 (4C, <sup>Ar</sup>C-2/6), 129.8 (4C, <sup>Ar</sup>C-3/5), 132.9 (2C, <sup>Ar</sup>C-4), 144.9 (2C, <sup>Ar</sup>C-1).

***N*-benzyl-octadeutero-morpholine (6):** Diethylene diglycol ditosylate-d<sub>8</sub> (**5**) (9.00 g, 21.30 mmol) was dissolved in 1,4-dioxane (120 ml) and magnesium sulfate (20 g) and benzylamine

(11.62 ml, 106.5 mmol) were added. The reaction mixture was heated at 100°C overnight. After cooling down, the solids were filtered off and the solvent was removed *in vacuo*. The crude product was purified by column chromatography, starting with EtOAc/*n*-hexane (*v/v* = 1:10). After removal of non-polar by-products, compound **6** was eluted with EtOAc/*n*-hexane (*v/v* = 1:2). Removal of the solvent provided **6** as a light yellow liquid (3.88 g, 98%). <sup>1</sup>H NMR: δ 3.50 (s, 2H, CH<sub>2</sub>), 7.21–7.29 (m, 5H, Ar-H). <sup>13</sup>C NMR: δ 53.4 (pent, N-CD<sub>2</sub>, *J*<sub>C,D</sub> = 22 Hz), 63.6 (Ph-CH<sub>2</sub>), 66.3 (pent, O-CD<sub>2</sub>, *J*<sub>C,D</sub> = 22 Hz), 127.1 (<sup>Ar</sup>C-4), 128.4 (2C, <sup>Ar</sup>C-3/5), 129.2 (2C, <sup>Ar</sup>C-2/6), 137.7 (<sup>Ar</sup>C-1). Comparison with the non-deuterated product (*N*-benzyl-morpholine). <sup>1</sup>H NMR: δ 2.43 (m, 4H, N-CH<sub>2</sub>), 3.48 (s, 2H, Ph-CH<sub>2</sub>), 3.70 (m, 4H, O-CH<sub>2</sub>), 7.24–7.32 (m, 5H, <sup>Ar</sup>H). <sup>13</sup>C NMR: δ 53.6 (N-CH<sub>2</sub>), 63.4 (Ph-CH<sub>2</sub>), 66.9 (O-CH<sub>2</sub>), 127.0 (<sup>Ar</sup>C-4), 128.2 (2C, <sup>Ar</sup>C-3/5), 129.1 (2C, <sup>Ar</sup>C-2/6), 137.7 (<sup>Ar</sup>C-1).

**Octadeutero-morpholine hydrochloride (7):** *N*-Benzyl morpholine-d<sub>8</sub> (3.88 g, 20.94 mmol) was dissolved in methanol (280 ml) and dichloromethane (150 ml) and Pd/C (2.21 g, 10%) were added. The reaction mixture was hydrogenated at ambient pressure under stirring until *N*-benzyl morpholine was completely consumed (TLC control). The reaction mixture was filtered over celite and the remainder was washed extensively with dichloromethane. The filtrate was concentrated *in vacuo*, and the crude product **7**, obtained as off-white solid (2.7 g, 98%), was used without further purification. <sup>1</sup>H NMR (D<sub>2</sub>O, neutralized to pH 7 with NaOD): δ 3.21 (bs, 2H). <sup>13</sup>C NMR (D<sub>2</sub>O, neutralized to pH 7 with NaOD): δ 46.0 (N-CD<sub>2</sub>, *J*<sub>C,D</sub> = 22 Hz), 67.4 (O-CD<sub>2</sub>, *J*<sub>C,D</sub> = 22 Hz). Comparison with the non-deuterated product (morpholine hydrochloride). <sup>1</sup>H NMR (D<sub>2</sub>O, neutralized to pH 7 with NaOD): 2.05 (s, NH), 2.87 (m, 4H, N-CH<sub>2</sub>), 3.68 (m, 4H, O-CH<sub>2</sub>). <sup>13</sup>C NMR (D<sub>2</sub>O, neutralized to pH 7 with NaOD): 46.5 (N-CH<sub>2</sub>), 68.1 (O-CH<sub>2</sub>).

***N*-methyl morpholine *N*-oxide-d<sub>11</sub> (9):** Hydrochloride **7** (2.70 g, 20.52 mmol) was dissolved in formic acid-d<sub>2</sub> (5.00 g) and paraformaldehyde-d<sub>2</sub> (1.00 g) was added to the solution. The reaction mixture was refluxed overnight. After cooling, 10% aqueous NaOH was added (pH = 10, control!), and the aqueous phase was extracted with dichloromethane repeatedly. At least 10 extractions were necessary to bring the *N*-methylmorpholine quantitatively into the organic phase. The combined organic extracts were dried over MgSO<sub>4</sub>, the solvent was removed, and an aliquot was taken for NMR analysis. To the crude product remainder, aqueous hydrogen peroxide (30%, 4.65 g) was added at 0°C, and the mixture was stirred for overnight at r.t. The remaining peroxide was destroyed by activated MgO<sub>2</sub>. The solids were filtered and washed with ethanol. The filtrate was concentrated *in vacuo*, the oily remainder was further dried *in vacuo* for 5 days. After sublimation in a Kugelrohr apparatus at 120°C in high vacuum, compound **9** was obtained as white powder (1.9 g, 72%).

***N*-trideuteromethyl-octadeuteromorpholine (8):** <sup>13</sup>C NMR: δ 45.4 (sept., N-CD<sub>3</sub>, *J*<sub>C,D</sub> = 18 Hz), 55.1 (pent, 2C, N-CD<sub>2</sub>, *J*<sub>C,D</sub> = 22 Hz) 66.4 (pent, O-CD<sub>2</sub>, *J*<sub>C,D</sub> = 22 Hz). Comparison with the non-deuterated product (*N*-methylmorpholine). <sup>1</sup>H NMR (CDCl<sub>3</sub>, 0.1 M): δ 2.32 (s, 3H, N-CH<sub>3</sub>), 2.41 ('t', 4H, N-CH<sub>2</sub>), 3.71 ('t', 4H, O-CH<sub>2</sub>). <sup>13</sup>C NMR (CDCl<sub>3</sub>, 0.1 M): δ 46.4 (N-CH<sub>3</sub>), 55.5 (2C, N-CH<sub>2</sub>), 66.9 (2C, O-CH<sub>2</sub>).

***N*-trideuteromethyl octadeutero-morpholine *N*-oxide (9):** <sup>1</sup>H NMR (CDCl<sub>3</sub>, 0.1 M): δ 3.72 (bs, H<sub>2</sub>O). <sup>13</sup>C NMR (CDCl<sub>3</sub>, 0.1 M): δ 60.6–61.4 (m, 3C, N-CH<sub>3</sub>, N-CH<sub>2</sub>), 65.2 (pent, 2C, *J*<sub>C,D</sub> = 22 Hz,

O-CH<sub>2</sub>). Comparison with the non-deuterated product (*N*-methylmorpholine *N*-oxide): reference.<sup>12</sup> <sup>1</sup>H NMR (CDCl<sub>3</sub>, 0.1 M): δ 3.11 (dd, 2H, N-CH<sub>eq</sub>), 3.27 (s, 3H, N-CH<sub>3</sub>), 3.38 (dt, 2H, N-CH<sub>ax</sub>), 3.78 (dd, 2H, O-CH<sub>eq</sub>), 4.45 (dt, 2H, O-CH<sub>ax</sub>). <sup>13</sup>C NMR (CDCl<sub>3</sub>, 0.1 M): δ 61.3 (N-CH<sub>3</sub>), 61.7 (N-CH<sub>2</sub>), 66.0 (O-CH<sub>2</sub>). Microanalysis: calcd. for C<sub>5</sub>D<sub>11</sub>NO<sub>2</sub> (128.21): C: 46.84, H 8.65; found: C: 46.75, H 8.88.

**Trideuteroacetic acid isopropyl ester (11):** To acetic acid-d<sub>4</sub> (5.0 g, 4.47 ml, 0.078 mol) and 2-propanol (7 ml, 0.091 mol) was added acidic ion exchanged resin (Dowex 50W, H<sup>+</sup> form, 100–200 mesh, 0.2 g). The mixture was stirred at r.t. for 30 min and refluxed for 2 h. After cooling to r.t., the catalyst was filtered off. The mixture was used for the subsequent ammonolysis without purification. NMR data were obtained by a sample purified by distillation over MgSO<sub>4</sub>. <sup>1</sup>H NMR: δ 1.23 (d, 6H, 2x Me), 5.02 (sept., 1H, CH(Me)<sub>2</sub>). <sup>13</sup>C NMR: δ 21.4 (sept., *J*<sub>C,D</sub> = 19 Hz, CD<sub>3</sub>), 22.0 (2x Me), 74.9 (Me<sub>2</sub>CH-O), 170.5 (COO). Comparison with the non-deuterated product (isopropyl acetate): <sup>1</sup>H NMR: δ 1.22 (d, 6H, 2x Me), 2.05 (s, 3H, CH<sub>3</sub> in Ac), 4.98 (sept., 1H, CH(Me)<sub>2</sub>). <sup>13</sup>C NMR: δ 21.8 (Me in Ac), 22.3 (2x Me), 75.0 (Me<sub>2</sub>CH-O), 171.4 (COO).

**Trideuteroacetamide (12):** The crude product obtained according to the above procedure was dissolved in ethanol (10 ml), cooled to 0°C, and dropped into a concentrated aqueous solution of ammonia (5 ml) at 0°C. After stirring for 30 min, the mixture was allowed to reach r.t. and was stirred for additional 30 min. The solvents were removed *in vacuo* at a bath temperature of 60°C. The remainder, which solidified upon cooling to r.t., was recrystallized twice from dry acetone to afford trideuteroacetamide (**12**, 3.01 g, 62% rel. to **10**). <sup>1</sup>H NMR: δ 4.50 (s, br, NH<sub>2</sub>). <sup>13</sup>C NMR: δ 19.6 (sept., *J*<sub>C,D</sub> = 19 Hz, CD<sub>3</sub>), 171.5 (CONH<sub>2</sub>). Comparison with the non-deuterated product (isopropyl acetate): <sup>1</sup>H NMR: δ 2.04 (s, 3H, Me), 4.25 (s, br, NH<sub>2</sub>). <sup>13</sup>C NMR: δ 20.3 (Me), 170.9 (CONH<sub>2</sub>).

**Nona-deutero-*N,N*-dimethylacetamide (14):** Deutero-paraformaldehyde (0.11 mol, 3.52 g) was dissolved in 40 ml of warm formic acid (60°C), and acetamide (3.0 g, 0.048 mol) was added. The mixture was refluxed for 24 h and fractionated under vacuum. The fraction containing mainly the desired product was redistilled under normal pressure to give neat DMAc-d<sub>9</sub> (**14**, 1.95 g, 0.02 mol, 42% rel. to **12**). For NMR data see below.

**Bis(trideuteromethylamine)-carbon dioxide complex (17):** In a stainless steel autoclave with Teflon coating, ammonium carbonate (7.81 g, 0.1 mol), tetradeuteromethanol (7.21 g, 8.12 ml) and acidic aluminum oxide (15.0 g) was heated to 350°C for 3 h under stirring. Even though the vessel contained no liquids at the temperature used, efficient agitation of the alumina was crucial to complete the reaction within the time used. The vessel was cooled to r.t. and carbon dioxide was introduced until a pressure of 5 bar was reached. After stirring for 10 min at r.t., the vessel was heated to 80°C and the gases slowly expanded into a trap cooled to about –10°C by a ice/NaCl mixture. After reaching atmospheric pressure, the autoclave was purged with a stream of nitrogen under stirring to desorb residual products from the alumina. In the cooling trap a colorless liquid condensed. The liquid was transferred into a flask and redistilled at a bath temperature of 80°C and a condenser temperature of 0°C to afford bis(trideuteromethylamine)-carbon dioxide complex (**17**, 7.50 g, 56% rel. to **15**). It should be pointed out again that this procedure is not a conventional distillation but a decomposition/reformation of a liquid addition complex of two gaseous components.



Dimcarb (**17**, 7.50 g) was transferred back into the autoclave. Acetic acid-d<sub>4</sub> (**10**, 3.6 g, 3.20 ml) and acidic alumina (Brockmann grade I, 2.0 g) was added, and the autoclave heated to 250°C for 1 h. After cooling to r.t. the mixture was transferred into a flask, removing reminders by washing with dichloromethane, and distilled twice at reduced pressure (5 Torr) to afford DMAC-d<sub>9</sub> (**14**, 5.38 g, 5.2 ml, 100% rel. to **10**) in pure form (GC control).

*Bis(trideuteromethyl)-dimcarb (17)*: <sup>1</sup>H NMR: δ 11.18 (s, NH, COOH). <sup>13</sup>C NMR: δ 35.6 (sept., J<sub>C-D</sub> = 24 Hz, N-CD<sub>3</sub>), 162.1 (COO). Comparison with the non-deuterated sample (dimcarb): <sup>1</sup>H NMR: δ 2.70 (s, br, 6H, N-CH<sub>3</sub>), 9.86 (s, 1H, NH, COOH). <sup>13</sup>C NMR: δ 36.0 (N-CH<sub>3</sub>), 164.0 (COO). The NMR spectra, which agree with the literature (non-deuterated dimcarb),<sup>13</sup> are the result of complex and fast dynamic equilibria.

*Nona-adeutero-N,N-dimethylacetamide (14)*: <sup>1</sup>H NMR (CDCl<sub>3</sub>, 0.1 M): δ 2.5 (s, br, H<sub>2</sub>O). <sup>13</sup>C NMR (CDCl<sub>3</sub>, 0.1 M): δ 20.8 (sept., J<sub>C,D</sub> = 19 Hz, CD<sub>3</sub>CO), 34.3 (sept., J<sub>C,D</sub> = 21 Hz, N-CD<sub>3</sub>), 37.2 (sept., J<sub>C,D</sub> = 21 Hz, N-CD<sub>3</sub>), 170.8 (CO). Comparison with the non-deuterated product (*N,N*-dimethylacetamide): <sup>1</sup>H NMR (CDCl<sub>3</sub>, 0.1 M): δ 2.08 (s, 3H, Me in Ac), 2.40 (s, br, H<sub>2</sub>O), 2.92 (s, 3H, N-CH<sub>3</sub>), 3.01 (s, 3H, N-CH<sub>3</sub>). <sup>13</sup>C NMR (CDCl<sub>3</sub>, 0.1 M): δ 21.2 (Me in Ac), 34.8 (N-CH<sub>3</sub>), 38.0 (Hz, N-CH<sub>3</sub>), 170.4 (CO). Microanalysis: calcd. for C<sub>4</sub>D<sub>9</sub>NO (96.18): C: 49.95, H 9.43; N: 14.56; found: C: 50.01, H 9.36; N: 14.32.

## Conclusion

The presented synthesis of perdeuterated NMMO (**9**) is highly reproducible, which was ensured for all steps by reaction optimization. Furthermore, the purification procedures used are rather simple – there is only one column chromatography of the benzyl-protected intermediate required in the whole reaction sequence. The final product is refined by sublimation or recrystallization. Only standard deuterated reagents, such as MeOD, NaOD, LiAlD<sub>4</sub>, (CD<sub>2</sub>O)<sub>n</sub>, and DCOOD, are involved.

Two alternative pathways for the synthesis of perdeuterated *N,N*-dimethylacetamide (**14**) were studied and optimized. The superior pathway involves ammonium carbonate as the source of ammonia, which is alkylated by methanol and further acylated by acetic acid in the gas-phase reactions. Separation and purification of the intermediate dimethylamine were achieved through its liquid and distillable adduct with carbon

dioxide. Also for the preparation of **14**, only standard deuterated reagents, such as CD<sub>3</sub>OD, CD<sub>3</sub>COOD, (CD<sub>2</sub>O)<sub>n</sub>, and DCOOD, were involved.

Besides having the advantages of high reproducibility and good yields, the syntheses presented in Scheme 1 and Scheme 2 have two distinct additional benefits: they are cheap and are able to provide gram amounts of the perdeuterated products, which is a crucial issue in the case of NMR studies.

## Acknowledgements

The financial support by the Austrian Fonds zur Förderung der wissenschaftlichen Forschung, project P-17426 is gratefully acknowledged. The authors would like to thank Dr Andreas Hofinger, Department of Chemistry at the University of Agricultural Sciences Vienna, for recording the NMR spectra. Furthermore, the authors are indebted to Dr Toshiyuki Takano and Dr Hiroshi Kamitakahara, Graduate School of Agriculture, Kyoto University, for their support during this project. We would like to thank Deutero GmbH, Kastellaun, Germany, for providing deuterated chemicals at reduced prizes.

## References

- [1] G. W. Buchanan, A. B. Driega, A. Moghimi, C. Bensimon, K. Bourque, *Can. J. Chem.* **1993**, *71*(7), 951–958.
- [2] M. Ouchi, Y. Inoue, T. Kanzaki, T. Hakushi, *J. Org. Chem.* **1984**, *49*(8), 1408–1412.
- [3] E. Licandro, S. Maiorana, A. Papagni, M. Pryce, A. Z. Gerosa, S. Riva, *Tetrahedron Asym.* **1995**, *6*(8), 1891–1894.
- [4] T. Rosenau, A. Potthast, J. Rohrling, A. Hofinger, H. Sixta, P. Kosma, *Synth. Comm.* **2002**, *32*(3), 457–459.
- [5] D. Koga, T. Imoto, Y. Nakamura, S. Fujikawa, K. Yagashita, *Agric. Biol. Chem.* **1978**, *42*(6), 1147–1156.
- [6] U. P. Kreher, A. E. Rosamilia, C. L. Raston, J. L. Scott, C. R. Strauss, *Molecules* **2004**, *9*, 387–393.
- [7] Patent DE 619754. I. G. Farbenind, **1933**.
- [8] W. Richarz, M. Lutz, A. Guyer, *Helv. Chim. Acta* **1959**, *42*, 2212–2210.
- [9] W. Richarz, M. Lutz, A. Guyer, *Helv. Chim. Acta* **1962**, *45*, 2154–2161.
- [10] T. A. Fedorova, V. A. Reshetov, M. I. Yakushin, L. S. Velichko, V. I. Kotov, *J. Appl. Chem. USSR (Engl. Transl.)* **1982**, *55*(9), 1968–1970.
- [11] J. R. Ruhoff, E. E. Reid, *J. Am. Chem. Soc.* **1937**, *59*, 402.
- [12] T. Rosenau, A. Hofinger, A. Potthast, P. Kosma, *Polymer* **2003**, *44*(20), 6153–6158.
- [13] R. Radeglia, J. Andersch, W. Schroth, *Z. Naturforsch.* **1989**, *44b*, 181–186.